



**M6 Phono
Signature**

PRE AMPLIFIER

OWNER'S INFORMATION



CONTENTS

- 1) IMPORTANT SAFETY INFORMATION**
- 2) CE DECLARATION OF CONFORMITY
DISPOSAL
POWER REQUIREMENTS**
- 3) INTRODUCTION**
- 4) OVERVIEW**
- 6) UNPACKING AND INSTALLATION**
- 7) CONNECTION**
- 15) OPERATION**
- 17) TECHNICAL SPECIFICATIONS**
- 18) WARRANTY INFORMATION**
- 19) CONTACT INFORMATION**

! IMPORTANT SAFETY INFORMATION !



Danger
Electric shock risk

RISK OF SHOCK OR ELECTROCUTION! INTERNAL OPERATING VOLTAGES ARE LETHAL!

Do not remove top cover, unless specifically instructed to do so in the user manual.

This unit contains fuses and other safety components in accordance with BS60065 requirements.

In the event of failure, replacement fuse or safety component must be of the same part type and value.

SUCH REPLACEMENT MUST ONLY BE CARRIED OUT BY A QUALIFIED SERVICE TECHNICIAN.

Do not attempt to replace any fuses without first disconnecting the unit from the mains electricity supply.

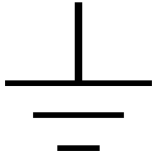

This product must be earthed – ensure that the mains supply cable earth / ground is correctly connected.



This product generates high levels of heat. Adequate ventilation must be provided. Do not restrict airflow through any ventilation slots or place the unit on any surface that may restrict airflow.

Valve equipment operates at extremely high temperatures;
KEEP OUT OF THE REACH OF CHILDREN AND ANIMALS.



Do not store or operate this unit in areas of high humidity or in close proximity to water / moisture.

Do not expose or immerse the unit in liquid of any kind.

OTHER SAFETY PRECAUTIONS: -

Never touch the power cord with wet hands.

Always remove the power cord by grasping the plug, not the cable.

Never expose the unit to excessive heat or magnetism.

Never let an inexperienced person repair or reassemble the unit.

Never put anything, especially metal objects, inside the unit.

Never place excessive weight on the unit.

CE DECLARATION OF CONFORMITY



We declare under our sole responsibility that this product is in conformity with the following standards or standardized documents:

BS EN 60065 in accordance with the regulations 73/23/EEC, 89/336/EEC (from 1 January 1997)

CE 94

Peter Qvortrup,
Director
Audio Note (UK) Limited
Viscount House
Star Road, Star Trading Estate
Partridge Green
West Sussex
RH13 8RA
United Kingdom

Tel: +44 (0)1273 830 800

Fax: +44 (0)1273 731 498



DISPOSAL

This product must not be disposed of as normal household waste. To prevent possible harm to the environment please separate the product from other waste to ensure that it can be recycled in an environmentally safe manner. Please contact your retailer or the appropriate local government office for collection facilities.

POWER REQUIREMENTS

Power requirements for electrical equipment vary depending on your geographical location. Please ensure that your unit meets the power requirements in your area. The power requirement for your unit is marked on the serial number plate, located on the rear panel.

If you are in doubt, please contact your dealer before plugging the unit into the mains supply.

INTRODUCTION

Thank you for purchasing this Audio Note (UK) product. With the correct care it should give you many years of pleasure and enjoyment.

Please take the time to read all of the information in this manual before connecting your new component to an electrical supply or your system, to ensure both your safety and satisfaction.

Please note that due to our desire to continually improve products, specifications are subject to change without notice. Therefore it is important to refer to the manual that is supplied with your product for the most accurate information; manuals downloaded from our website or obtained from other sources may no longer fully apply to your product.

If you have any questions regarding the information contained within this document or your new component, please feel free to contact us: -

Audio Note (UK) Limited
Viscount House
Star Road, Star Trading Estate
Partridge Green
West Sussex
RH13 8RA
United Kingdom

Tel: +44 (0)1273 830 800
Fax: +44 (0)1273 731 498
e-mail: info@audionote.co.uk
www.audionote.co.uk



M6 PHONO SIGNATURE PRE AMPLIFIER

Congratulations on your purchase of the Audio Note (UK) M6 Phono Signature preamplifier. It is without doubt or question, one of the finest preamplifiers in production today and is a full Audio Note (UK) Level 4 product.

It is well known that the accurate reproduction of music, not just sound, requires the purity of the incoming signal to be preserved. It is therefore not difficult to conclude that, in order to achieve this goal and to retain the musicality of the original performance, the complexity of the circuitry itself must be kept to a minimum.

In response to this, the M6 Phono Signature preamplifier uses a single-ended, zero feedback circuit topology. This is simply the most linear design possible, demanding pure Class A valve operation and removing the need for a phase splitter, which introduces unnecessary crossover distortion.

In contrast to the majority of the audio industry, we design our circuits with the aim of minimising non-harmonic and time base anomalies, rather than producing vanishingly small harmonic or low intermodulation distortion measurements. These non-harmonic amplitude and time base distortions have a highly perceptible and adverse affect on the signal waveform, and it is far more important to address these factors than participate in the increasingly irrelevant numbers game that chases 'perfect measured response'.

As a result, the M6 Phono Signature was designed for maximum linearity and minimum transient distortion, and avoids the need for detrimental 'corrective' measures, such as inherently error-prone feedback loops.

M6 PHONO SIGNATURE PRE AMPLIFIER continued...

The M6 Phono Signature features a 6189 and 7044 equipped line stage, and also includes an exceptionally fine Moving Magnet phono stage, which uses three 5670 valves and Audio Note (UK) Copper Foil signal capacitors. A dedicated separate power supply is provided for each channel, housed in an external, full size chassis.

As one would expect, the output transformers for the M6 Phono Signature are fully designed and hand manufactured in-house by our skilled engineers. Each transformer has a copper primary and a silver secondary, built on our own UHiB double C-Cores.

Rather than using separate controls for volume and balance, the M6 Phono Signature is equipped with a dedicated Audio Note (UK) custom resistor based stepped attenuator for each channel. This not only brings the enormous improvements in sound quality expected from our stepped attenuators, but also provides a level of channel balance accuracy that is impossible to achieve with conventional volume and balance potentiometers.

The M6 Phono Signature also features a pair of correctly engineered balanced / XLR inputs for sources with suitable balanced outputs. Each input is connected directly to an in-house custom designed and produced, copper / silver wired input transformer, which offers the finest possible input for your XLR Line level source outputs.

As a fully specified Level 4 product, the M6 Phono Signature features the following exceptional component selection: -

- Audio Note (UK) 2 Watt Non-Magnetic Tantalum Resistors in critical areas
- Audio Note (UK) 1 Watt Non-Magnetic Tantalum Resistors in critical areas
- Audio Note (UK) Copper Foil / Mylar capacitors in all critical areas
- Audio Note (UK) KAISEI NP Electrolytic Capacitors
- Blackgate electrolytic capacitors in critical areas

UNPACKING AND INSTALLATION

Please take care when unpacking your M6 Phono Signature preamplifier. Choose a clean, clear location to unpack the units. Be aware that the preamplifier and its power supply are heavy; before attempting to unpack or lift the units, check the weight and if necessary use more than one person so that they can be moved safely and easily.

We recommend that you retain and carefully store all of the original packing materials, in case transportation / shipping is required at a later date.

Select a suitable location for the units. This should be a dry, dust free and level area, preferably shielded from direct sunlight and free from vibration. Also ensure that the location is stable and capable of carrying the weight of the units.

A suitable mains power outlet must be close to the location; power cords must not be pulled or stretched tightly in an attempt to reach a wall socket. If the power cords will not easily reach the socket, choose a closer location!

Please ensure that adequate ventilation for the units is provided, and that airflow through any ventilation slots in the casework is not restricted. We recommend a distance of at least 20cm free space is maintained above the units. It's possible to use the two chassis stacked on top of each other, but better performance – and heat regulation – will be achieved by placing each chassis on a separate shelf. Please also remember that valve equipment operates at extremely high temperatures, so a position that is inaccessible to children or animals is essential.

CONNECTION OVERVIEW

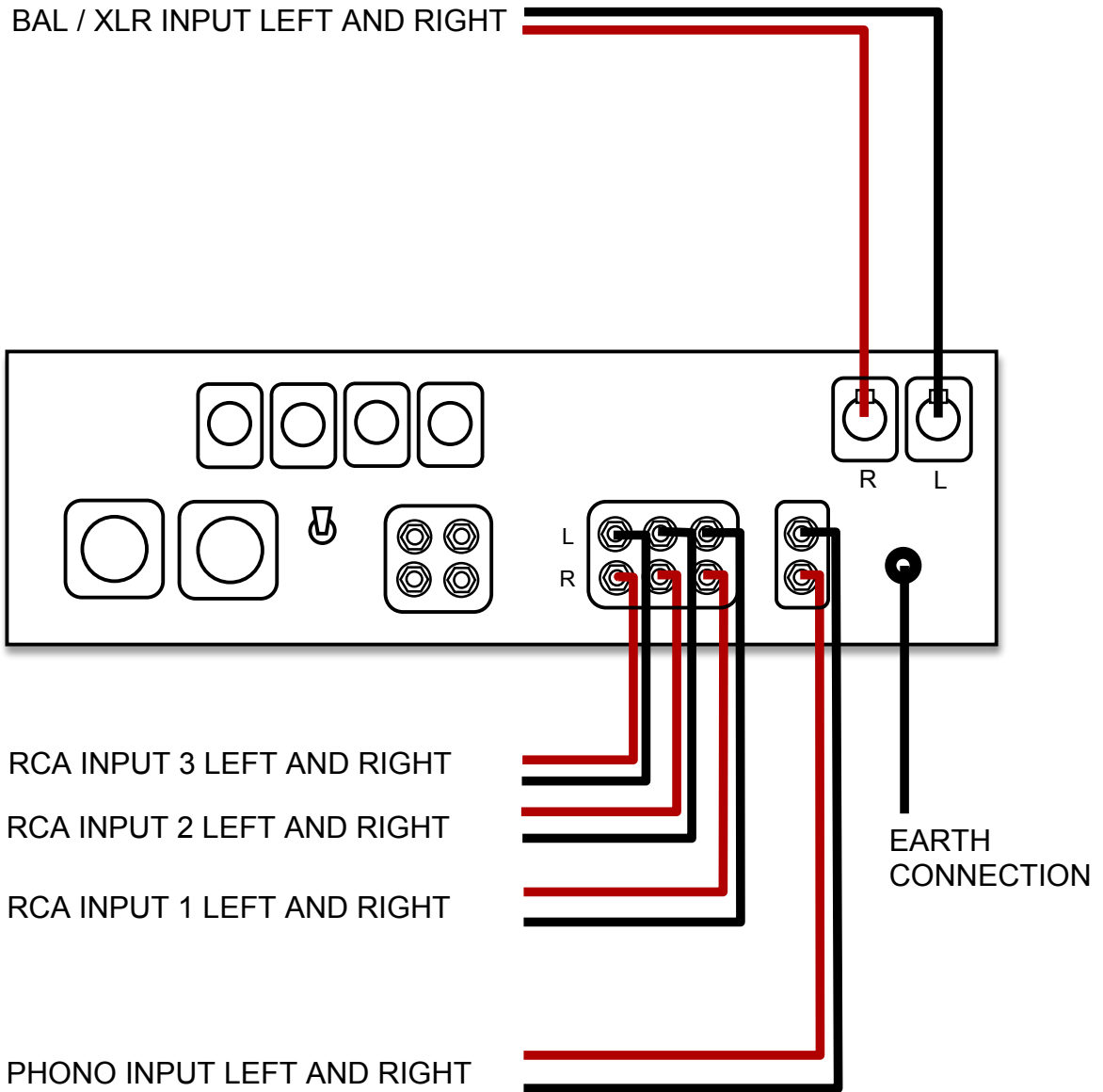

CONNECTION OVERVIEW continued...

RCA Inputs Three RCA / Single Ended line inputs are available for connection, labeled '1', '2' and '3'; any standard 'line level' source can be connected to these inputs.
All sockets are colour coded; **RED** is for RIGHT channel connection, **WHITE** is for LEFT channel connection.

XLR Input In addition to the three RCA inputs, an XLR / Balanced input is provided, for the connection of sources with the appropriate XLR / Balanced outputs. The sockets are connected to a pair of extremely high quality Audio Note (UK) Balanced input transformers, which offer the best possible connection for correctly designed Balanced equipment.
The sockets are marked 'R' for the right input and 'L' for the left input, and the 'BAL' position on the input selector activates them.

Phono input The M6 Phono is equipped with a high quality, valve, Moving Magnet (MM) phonostage. Connect the cables from your tonearm to the 'Phono' socket inputs. If your turntable or tonearm is equipped with a separate earth wire, connect this to the dedicated grounding / earth post, located next to the 'Phono' input sockets.

If you wish to use a low output Moving Coil (MC) cartridge, Audio Note (UK) manufactures a series of Step Up Transformers for this purpose. For further information, please contact your Audio Note (UK) Dealer, or alternatively please contact us directly.

Umbilicals Two dedicated cables are supplied for connection of the M6 Phono Signature main unit to the power supply. Each cable is colour coded for left and right connection.

IT IS ESSENTIAL THAT THE CORRECT POWER SUPPLY OUTPUT IS CONNECTED TO THE CORRECT CORRESPONDING INPUT ON THE MAIN UNIT.

Make sure you have correctly identified the corresponding power outputs / inputs before any connections are made.

The cables are fitted with Military specification circular connectors, and can only be installed in one direction; the female connectors attach to the power supply 'power out' sockets, the male connectors attach to the M6 Phono Signature main unit 'power supply input' sockets. The connectors are a 'push and twist' bayonet design, and once the connector and socket have been aligned, twist the external ring on the connector to secure it to the socket.

If you are in any way uncertain regarding these connections, please consult your official Audio Note (UK) dealer / supplier.

CONNECTION OVERVIEW continued...

M6 PHONO SIGNATURE UMBILICAL CABLE CONNECTION

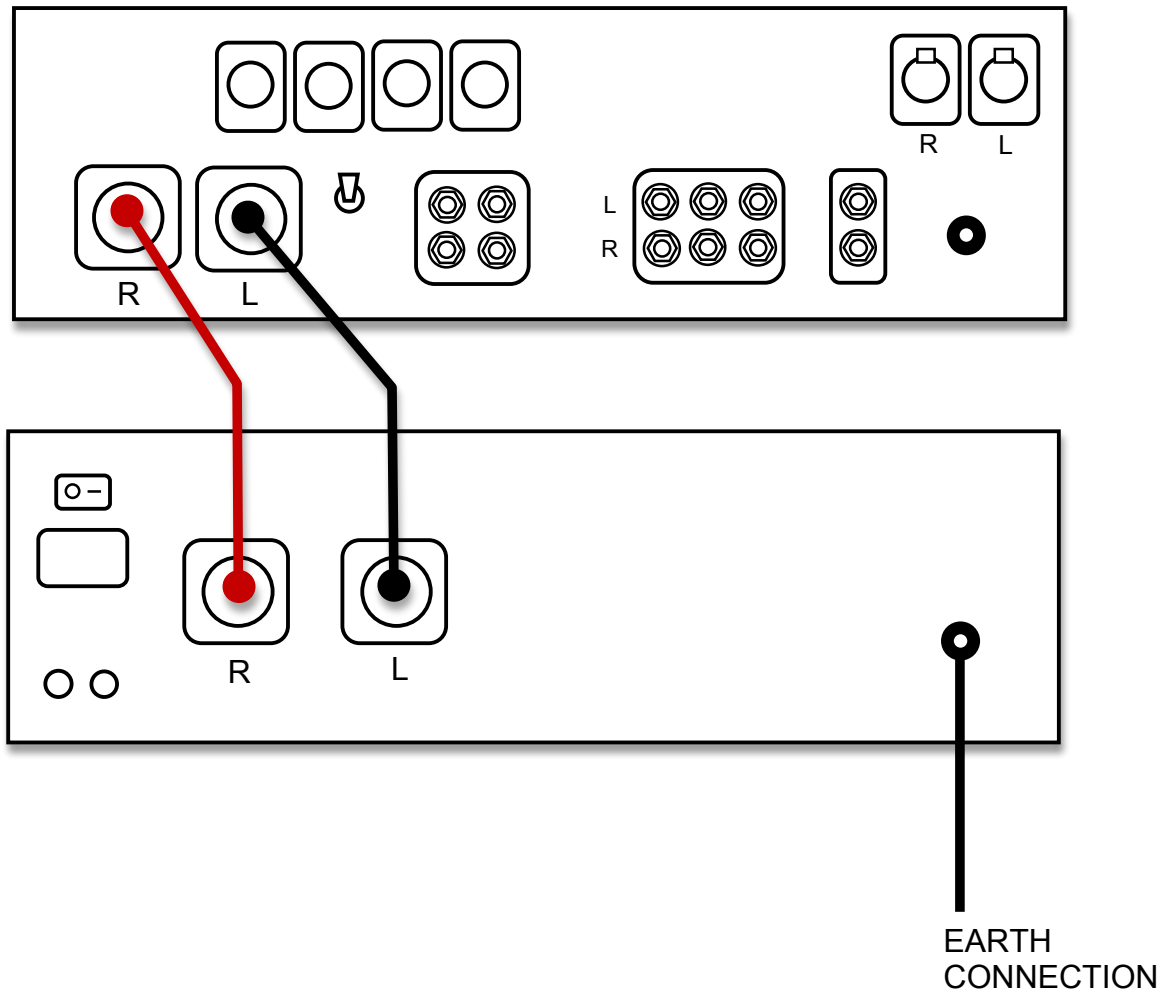

Ground Post Each chassis is fitted with a separate Earth connection / ground post. The post located on the main preamplifier unit is for connection to source components that also use a separate ground terminal. The ground post located on the power supply can be used in situations where the following amplifiers require a separate ground connection to maintain quiet, hum free operation. Please consult your official Audio Note (UK) dealer for further information on how best to use these in your system.

CONNECTION OVERVIEW continued...

Mains The M6 Phono Signature preamplifier power supply is equipped with an IEC 320 mains inlet socket. Use the supplied mains cable to connect the unit to the local mains supply. The mains fuses are located in the circular receptacles below the mains inlet.

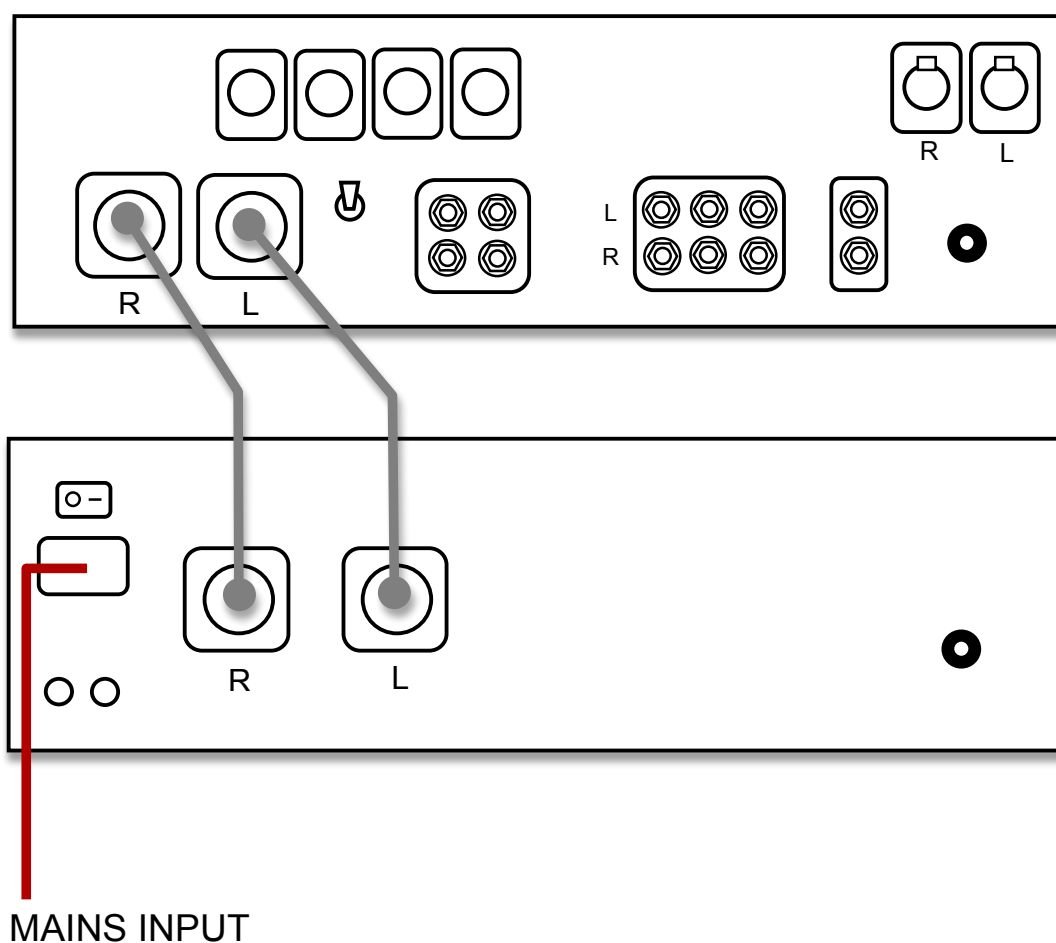

CONNECTION OVERVIEW continued...

Outputs The M6 Phono Signature preamplifier is equipped with two pairs of Single Ended / RCA outputs, consisting of two colour coded pairs of RCA / Single Ended sockets. **RED** is for RIGHT channel connection, **WHITE** is for LEFT channel connection.

There are also two pairs of balanced outputs, each consisting of a pair of 'male' XLR sockets (see 'Balanced' section, below).

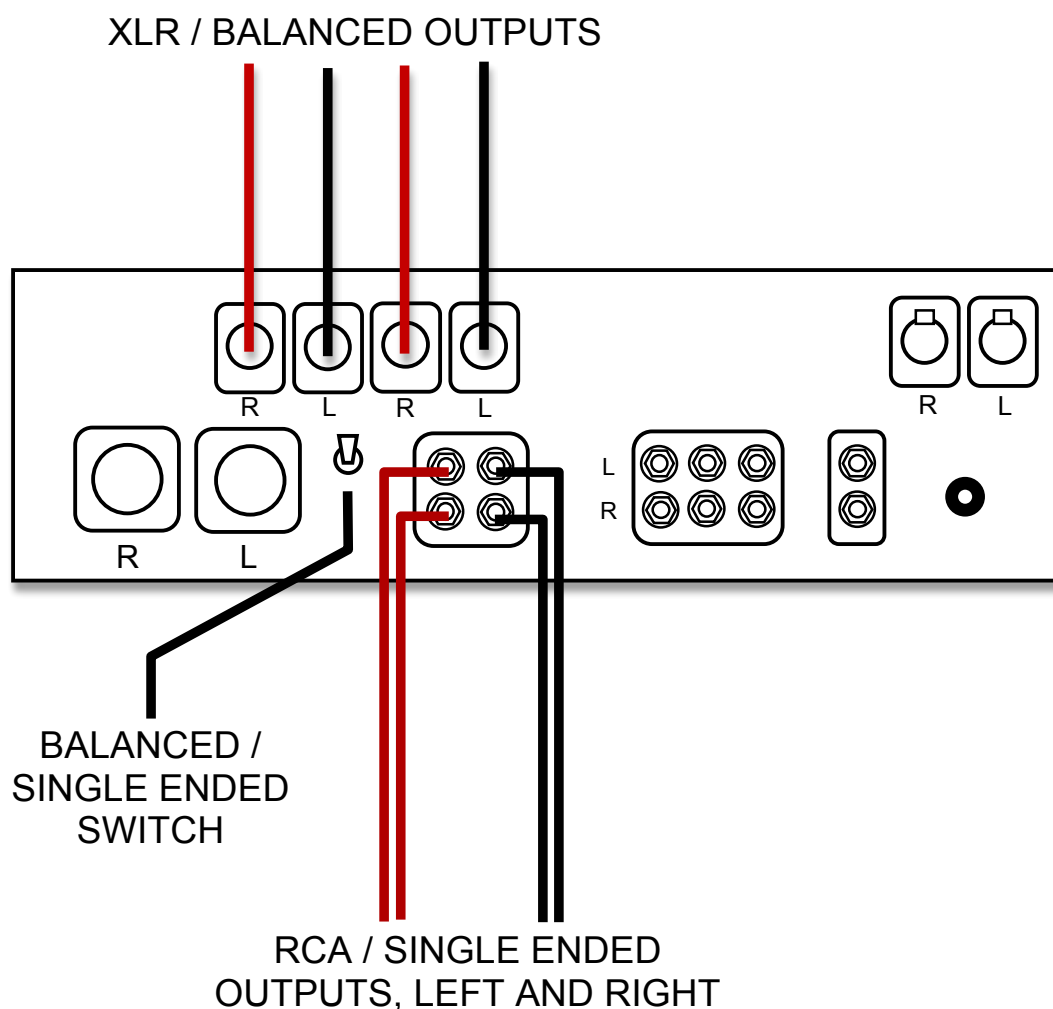

CONNECTION OVERVIEW continued...

RCA

The two pairs of RCA / Single Ended outputs are provided for connection to power amplifiers. They are identical, making them suitable for bi-amping.

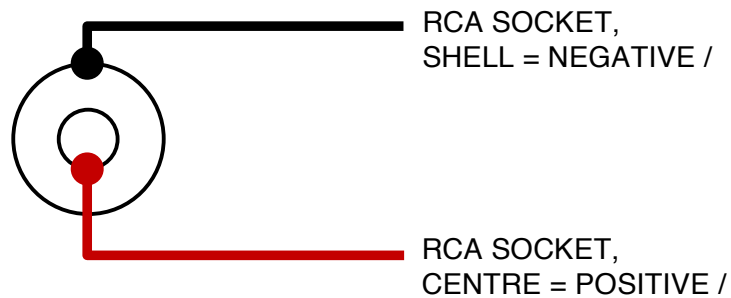

Balanced

The M6 Phono Signature preamplifier is equipped with custom designed and manufactured output transformers, which feature an improved output and grounding scheme to provide the best possible connection to the power amplifier.

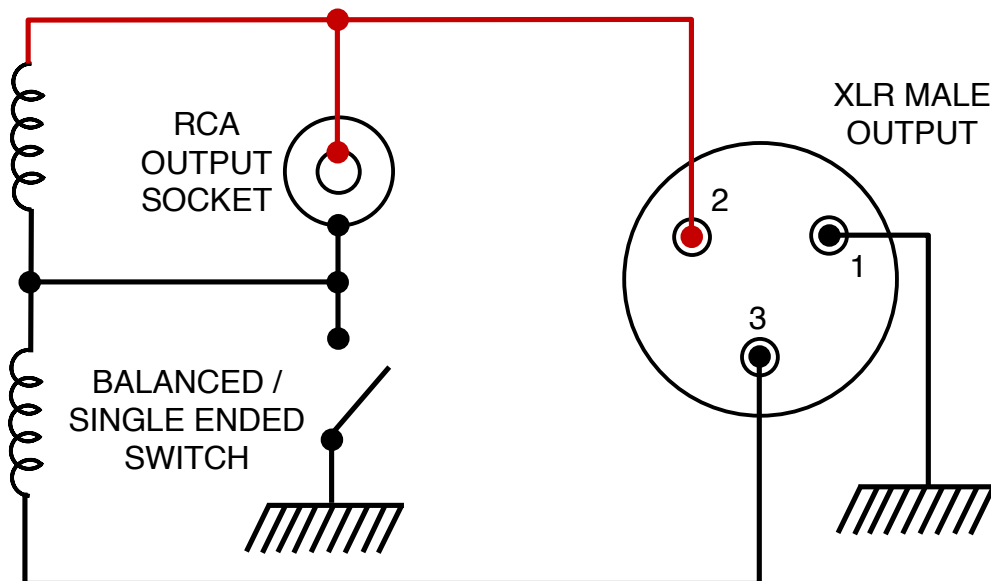

CONNECTION OVERVIEW continued...

The pin configuration for all Audio Note (UK) XLR / BALANCED connections is as follows: -

PIN 1	Ground / Shield
PIN 2	Positive / Send
PIN 3	Negative / Return

The balanced and single ended outputs cannot be used simultaneously; select the appropriate output using the toggle switch.

When using an amplifier with a true balanced input, the 'BALANCED / SINGLE ENDED' switch may be set in either position. When set to the 'BALANCED' position, the centre tap of the output transformer secondary is connected to the preamplifier's ground. When set in the 'SINGLE ENDED' position, the secondary 'floats' in relation to the preamplifier ground. This provides the option of either a low or high common mode impedance to ground at the preamplifier output. Experiment with both positions to achieve the lowest background hum from the system.

Special Note – Make sure that all connections are tight and clean. For best results use good quality audio interconnects. Although it is perfectly possible to use cables manufactured by other companies, for best results and performance, we recommend our own Audio Note (UK) range of interconnects and loudspeaker cables. For further information, please consult your nearest Audio Note (UK) dealer, or alternatively please feel free to contact us directly.

The following page provides a description of the various cable and connection options when connecting the XLR / Balanced outputs to various power amplifier inputs.

CONNECTION OVERVIEW continued...

CABLE CONFIGURATION OPTIONS

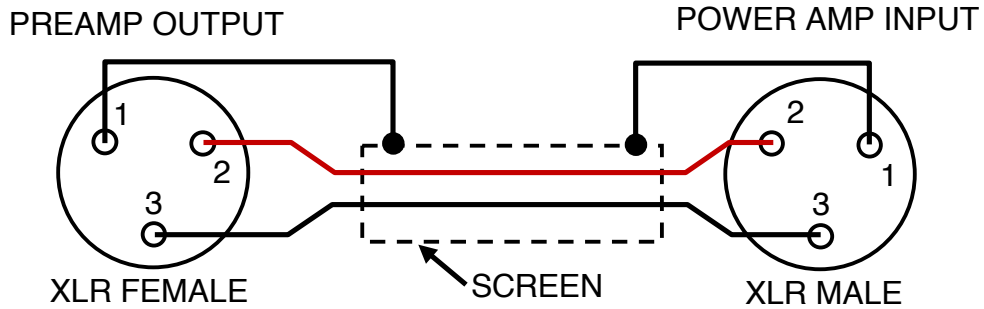

CONVENTIONAL: SCREEN CONNECTED AT BOTH ENDS

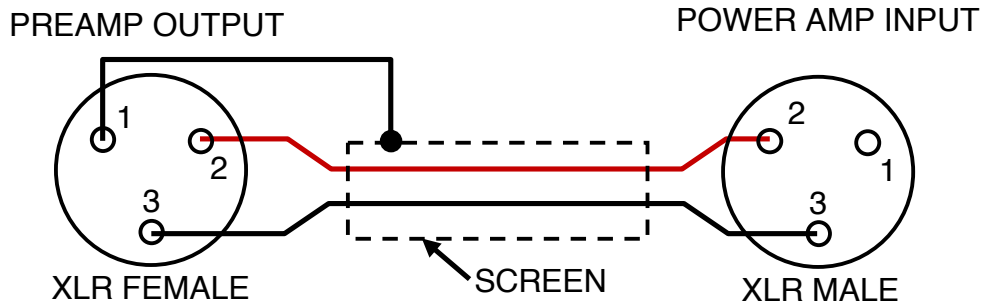

SCREEN CONNECTED AT PREAMP END ONLY, TO ELIMINATE GROUND LOOPS

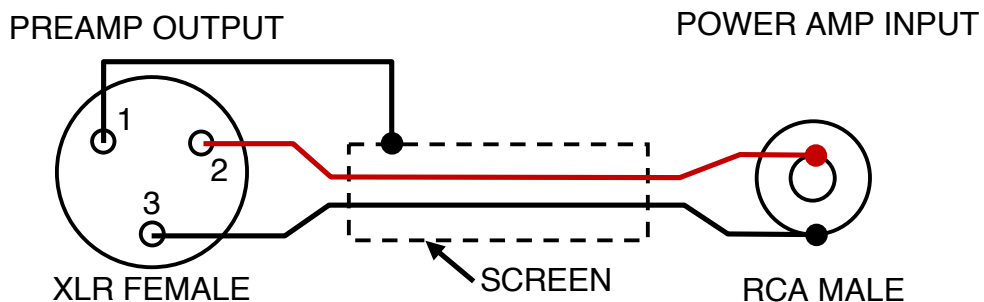

CABLE CONFIGURATION FOR XLR BALANCED PREAMP OUTPUT TO RCA UNBALANCED AMPLIFIER INPUT

When connecting the **XLR / BALANCED** outputs to an amplifier with an **RCA / Single Ended** input, the switch must be set to the **'SINGLE ENDED'** position.

OPERATION

Once all the connections are completed and checked, ensure that the volume controls are at the minimum setting (rotated all the way left).

Ensure that all source components connected to the M6 Phono Signature preamplifier are switched ON. Source components should always be the **FIRST** components to be switched on and the **LAST** components to be switched off.

Ensure that all power amplifiers connected to the M6 Phono Signature preamplifier are switched OFF. Any power amplifiers in use should be the **LAST** components to be switched on, and the **FIRST** components to be switched off.

The above procedure minimizes the possibility of loud noises produced by components at switch on being passed to the loudspeakers and possibly causing damage.

Turn on the M6 Phono Signature preamplifier by using the rocker switch located on the rear panel of the power supply unit, above the mains inlet IEC socket.

The M6 Phono Signature preamplifier requires approximately 45 seconds to initialize before it is ready for operation.

Input Selector Turn the selector to the source you wish to listen to.

Volume Controls There are two separate volume controls, one dedicated to each channel. For a correctly produced Stereo or Mono recording, adjust both channels to the same level. If it is necessary to equalize the relative levels for each channel, adjust the controls separately to achieve the desired balance.

OPERATION continued...

Bedding in

The new preamplifier requires around 200 hours of initial use (called “bedding in”) before the circuitry becomes stable and optimum performance is realized.

As the preamplifier “beds in” the sound will become increasingly smoother, detailed and more open.

Once the amplifier has “bedded in” a warm up time of approximately 20 to 30 minutes is required each time the amplifier is switched on before optimum sonic performance is reached.

Cleaning

No special maintenance is required for the preamplifier. Use a soft, clean lint free cloth to remove any surface marks from the casework. For finger marks / grease, use a soft, clean lint free cloth, lightly moistened with a solution of warm water and mild detergent. Do not use any alcohol or solvent based cleaning products, as they may damage the finish of the amplifier.

ENSURE THAT THE PREAMPLIFIER IS SWITCHED OFF AND DISCONNECTED FROM THE MAINS ELECTRICITY SUPPLY BEFORE UNDERTAKING ANY CLEANING.

Valve Life

The valves supplied with your M6 Phono Signature preamplifier should provide approximately 6000 hours of operation. They are specially selected by us, and should only be replaced with valves of the same type and specification. Please consult your Audio Note (UK) dealer, should your valves need replacing. Alternatively, feel free to contact us directly.

TECHNICAL SPECIFICATIONS

INPUT IMPEDANCE	100K Ohms Line 47K Ohms Phono
INPUT SENSITIVITY	110mV Line 0.32mV Phono
GAIN	Line: 16dB at 1KHz Phono: 68dB at 1KHz
OUTPUT IMPEDANCE	600 Ohms
OUTPUT NOISE	-80dB un-weighted (RMS)
VALVE COMPLEMENT	1 x 6189 (line stage) 1 x 7044 (line stage) 3 x 5670 (phono stage) 2 x 5651 (PSU) 2 x 6X5 (PSU) 2 x ECL82 (PSU)
FUSE RATINGS	1.6A anti-surge (110 / 120V supply) 800mA anti-surge (220 / 240V supply)
MAX. POWER CONSUMPTION	170 VA
TOTAL WEIGHT	30 KG (two units)
TOTAL SHIPPING WEIGHT (ORIGINAL PACKAGING)	40 KG
UNIT DIMENSIONS (2 X CHASSIS)	140mm (h) x 440mm (w) x 410mm (d) 140mm (h) x 440mm (w) x 410mm (d)
PACKAGING DIMENSIONS (2 X BOXES)	220mm (h) x 570mm (w) x 520mm (d) 220mm (h) x 570mm (w) x 520mm (d)
NOTE	Due to Audio Note (UK)'s ongoing research and development program, specifications are subject to change without notice.

WARRANTY INFORMATION

Audio Note (UK) warrants this product to be free from defects in materials and workmanship for two years from the original date of purchase from an appointed Audio Note (UK) dealer, and agrees to cover the cost of parts and associated labour required to correct such defects, subject to terms & conditions.

This Warranty is offered to the first purchaser only.

Any valves supplied with the unit are warranted for three months from the original date of purchase.

If the product fails in normal domestic use and during the Warranty period due to the above described faults or defects, Audio Note (UK) will, at its discretion, repair or replace the item free of charge within a reasonable time once it has been returned to Audio Note (UK) or an appointed Audio Note (UK) dealer or service engineer.

Audio Note (UK) is not liable for any shipping charges incurred whilst transporting the product to or from Audio Note (UK) or an appointed Audio Note (UK) dealer or service engineer, should the item require service or repair during or after the Warranty period.

If the product must be shipped, please use the original packaging materials and include a copy of the original sales receipt along with a note explaining, in as much detail as possible, the problems you are experiencing with the unit.

Only use a reputable Courier Service or Shipping Agent, and ensure that your product is insured during transit.

Any servicing, repairs or modifications not authorized by Audio Note (UK), or carried out by persons other than appointed Audio Note (UK) service engineers will invalidate any warranty.

This Warranty does NOT cover: -

Damage sustained whilst in the possession of a shipping agent, retailer or consumer and not caused as a direct result of defects in materials or workmanship.

Damage caused by normal wear and tear.

Damage or defects caused by abnormal or unreasonable use.

Damage caused by accident, acts of nature, misuse or neglect.

Damage caused by a failure to follow the operating and installation instructions supplied with the product.

Damage caused by improper or careless cleaning.

Audio Note (UK) reserves the right to refuse warranty for any component of which the serial number has been removed, defaced or tampered with.

CONTACT INFORMATION

If in the future your Audio Note (UK) product requires servicing, or if you require technical support or have any questions regarding this or any of our other products, please contact your local Audio Note (UK) dealer.

Alternatively, please feel free to contact us directly: -

Audio Note (UK) Limited
Viscount House
Star Road, Star Trading Estate
Partridge Green
West Sussex
RH13 8RA
United Kingdom

Tel: +44 (0)1273 830 800
Fax: +44 (0)1273 731 498
e-mail: info@audionote.co.uk
www.audionote.co.uk

